

WATER TROUGH Available in stainless steel sizes 48" - 144"

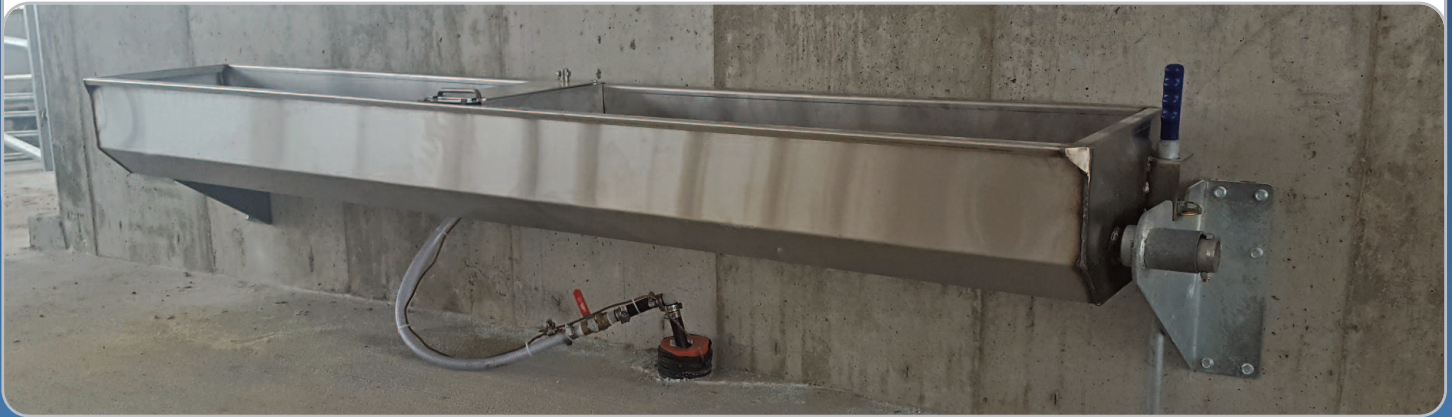

HEATED LIVESTOCK WATERER

Available models: H50, HL50, H100, H200



POLY WATERER

Model: P25, P50, P100



AQUA BOWL

Provides fresh water year around including below freezing temperatures

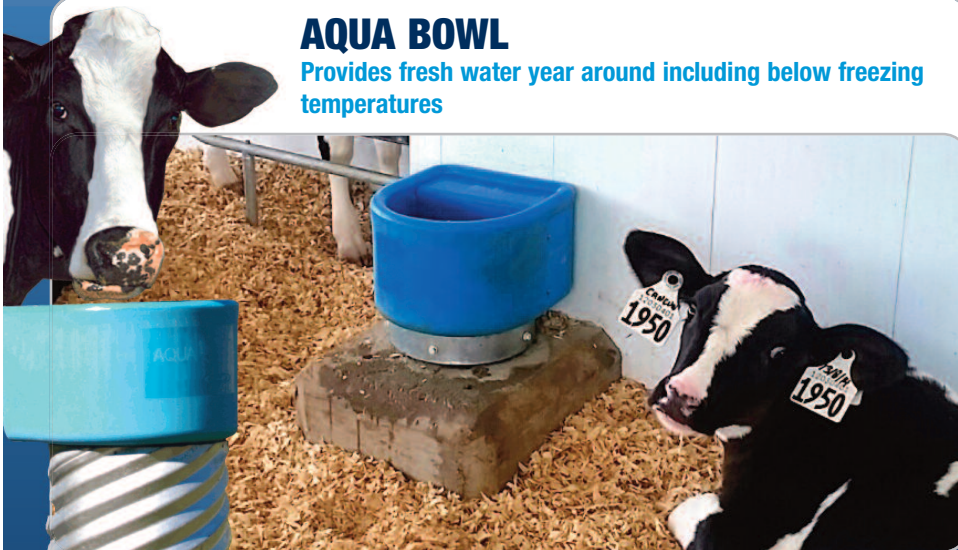

TIPPABLE SSH20 SINGLE HEAD WATERER

Single head waterer for calves and cows

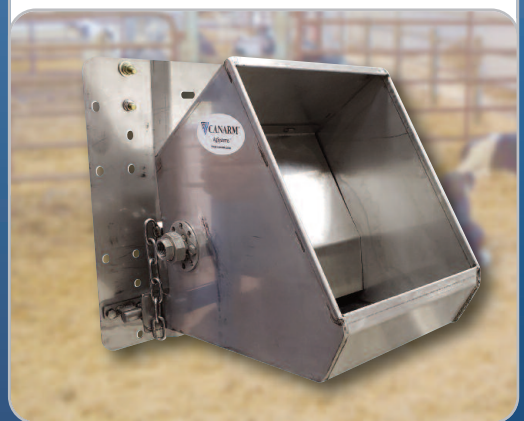

CANARM LTD. - Corporate Office
2157 Parkedale Ave., Brockville, ON
Canada K6V 5V6
Tel: (613) 342-5424 Fax: 1-800-263-4598

Web Site: www.canarm.com

CANARM LTD. - USA Warehouse
808 Commerce Park Drive
Ogdensburg, New York, USA 13669
Tel: 1-800-267-4427 Fax: 1-800-263-4598

E-Mail: agsales@canarm.ca

Arthur Manufacturing Facility
#7686 Concession 16, RR 4 Arthur, ON
Canada NOG 1A0
Tel: (519) 848-3910 Fax: (519) 848-3948



FACT

Recent studies have shown that there is less bacterial growth on stainless steel water tanks.

All your cows should have access to fresh water after being milked to maximize water intake. With Canarm AgSystem's tip trough your cows can have easy access to clean drinking water to keep them healthier and give more milk.

FEATURES

- Tip the trough to keep your cows water supply clean.
- Protect your equipment investment by choosing our high quality, durable heavy gauge troughs.
- Available in 4, 6, 8, 10 & 12 FT stainless steel troughs. If you need a tip trough of another size, contact us and we will make a tip trough to fit your barn.
- Hi-flo float system which refills whenever the float drops. Our float system has a steel guard that stops cows from playing with the float mechanism.

CAPACITIES

- 4 FT = 18 Gals at recommended 7" water depth
- 6 FT = 28 Gals at recommended 7" water depth
- 8 FT = 38 Gals at recommended 7" water depth
- 10 FT = 48 Gals at recommended 7" water depth
- 12 FT = 58 Gals at recommended 7" water depth

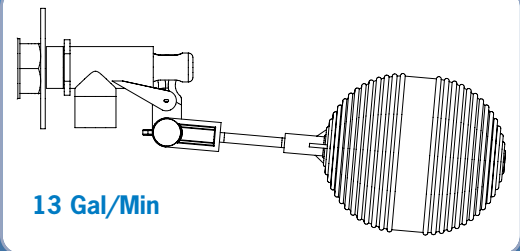

TIPPABLE SINGLE HEAD WATERER FOR CALVES AND COWS

An innovative new product – part of Canarm's water source solution.

FEATURES

- New tippable design for easy emptying
- Float controlled water flow - protected from animals
- Made from durable stainless steel, resisting corrosion
- Low maintenance and easy to clean
- Stainless steel reduces bacteria growth.
- An easy way to provide multiple watering locations throughout the barn and at the feed bunk.
- Suitable for all age groups.
- Universal mount.
- Max water volume: 12.37 liters or 3.266 gallons.
- 13 gpm float valve (49L/min).

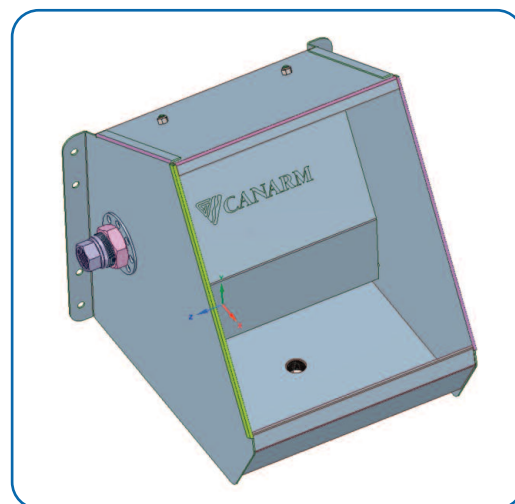
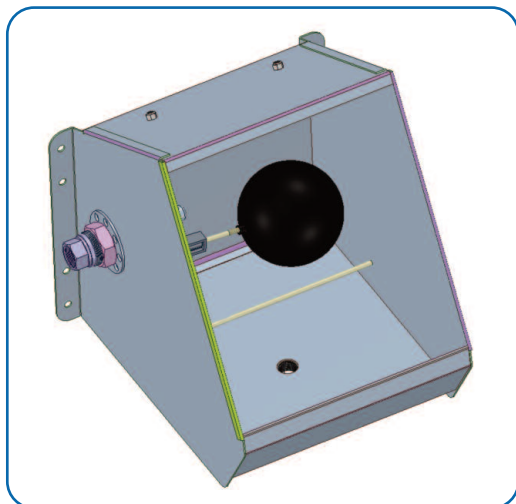



Canarm's Energy Efficient Heated Livestock Waterers are designed for both durability and ease of use.

2" INSULATION (R15)

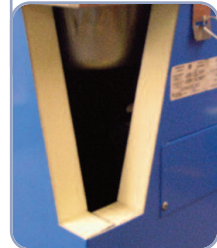

FLOAT & VALVE ASSEMBLY



Our strong, double wall design, combined with 2" of injected polyurethane foam insulation, gives an R15 insulation value, one of the highest in the industry. **The new Poly option for the 50 head waterer has a R18 insulation value!**

Based on PAMI testing our HL50 and H100 were rated #1 for energy savings. The energy cost for the winter season on our HL50 model proved to be almost 3 times more efficient than the competitive models tested at the same time. Our H50, HL50 and H100 are now designed with more than twice the amount of insulation than the models tested by PAMI.

The hinged bowl is designed to lift up for easy cleaning, as well as quick access to all internal components. Stainless steel bowl construction ensures long life, and eliminates the risk of chipping paint and rust contamination. Canarm heated livestock waterers come with either a 300 watt or 500 watt thermostatically controlled heating element. An external pilot light (there is no pilot light on the P50), which is visible from a distance, glows when the heater is operating. The thermostat is adjustable and can be accessed through the control cover. The nylon control valve is designed for trouble free, year around operation.

FEATURES

H50

- 2" foam insulation - R15
- Pilot light glows when unit in operation
- Waters up to 50 cattle
- 120V, 300 watt element
- 24" H x 26 1/2" L x 16 1/2" W
- 5.5 GPM @ 30 PSI
- 2.5 AMPS
- 1 year warranty

H100

- 2" foam insulation - R15
- Pilot light glows when unit in operation
- Waters up to 100 cattle
- 120V, 500 watt element
- 24" H x 31" L x 22" W
- 5.5 GPM @ 30 PSI
- 4.2 AMPS
- 1 year warranty

HL50

- 2" foam insulation - R15
- Pilot light glows when unit in operation
- Waters 50 cattle or 200 sheep
- 120V, 300 watt element
- 12" H x 26 1/2" L x 16 1/2" W
- 5.5 GPM @ 30 PSI
- 2.5 AMPS
- 1 year warranty

H200

- 2" Injected structural foam insulation – R15
- Pilot light glows when unit in operation
- Waters up to 200 Head of Cattle
- Hi Flow valve design 12 GPM @ 30 PSI pressure for faster fill.
- 120V, 500 watt + 300 watt element
- 24" H x 41 5/8" L x 23 3/4" W
- 4.2 AMPS
- 1 year warranty

RUGGED • ENERGY EFFICIENT • ANIMAL FRIENDLY • ECONOMICAL



HEATED POLY WATERERS

- Durable poly cabinet resists corrosion for years of service.
- Stainless steel top and poly cabinet will never rust.
- Comes with seamless stainless bowl.
- Stainless steel bowl construction ensures long life, and eliminates the risk of chipping paint and rust contamination.
- Thicker cabinet wall for a superior R value (R18).
- Mounting corners molded inside the cabinet make for easy installation and removal.
- Bowl has rounded corners that provide a durable yet smooth surface that is gentle on animals.
- Comes with a thermostatically controlled heating element.
- Electrical box hinges open from the inside for easy access to components.
- Adjustable thermostat.
- Nylon control valve is designed for trouble free, year around operation.
- 1 year warranty

FEATURES

P25

- 2" PLUS foam insulation – R18
- UV resistant Polypropylene
- Waters 25 cattle or 100 sheep
- 120V 180 watt element
- 18"H x 20"L x 20"W
- 5.5 GPM @ 30PSI
- 1.6 Amps

P50

- 2" PLUS foam insulation - R18
- UV resistant Polypropylene
- Waters 50 cattle or 200 sheep
- 120V, 300 watt element
- 24" H x 29" L x 19" W
- 5.5 GPM @ 30 PSI
- 2.5 AMPS

P100

- 2" PLUS foam insulation – R18
- UV resistant Polypropylene
- Waters 100 cattle
- 120V 500 watt element
- 24"H x 34"L x 25"W
- 5.5 GPM @ 30PSI
- 4.2 Amps

AQUA BOWL HEATED LIVESTOCK WATERING BOWL



Provides continuous fresh water all winter and summer. Designed especially for below freezing conditions.

The Aqua Bowl is a rugged, reliable waterer designed to keep your cows hydrated in harsh conditions, including below freezing temperatures. It keeps water circulating to prevent it from freezing while saving energy.

FEATURES

- Fully equipped with a heater, thermostat, infeed line heating wire and reliable float valve.
- It is sized to adequately water cows in groups in the field or individually in stalls.
- The font replenishes quickly, thus eliminating icing.
- Constructed of heavy duty, double walled poly, this bowl is rugged and able to withstand the elements for years of trouble-free performance.
- The inside is very easy to clean with an efficient drain.
- Thermal switch turns heater on at 5°C and off at 15°C to keep drinking water from freezing, yet not overheating, which saves on electricity and energy costs.
- All electrical components are sealed in epoxy to prevent shocks.

APPLICATIONS

The versatile shape of the unit allows it to be easily mounted both indoors and out. It is designed to fit snugly into an upended culvert for outdoor use, or it can be mounted with a wall bracket for use in stalls, building sides or posts. See installation details below.

HOW IT WORKS

Convection Circulation

The heating element creates a convection current in the water, which allows warm water to replace cold water on the exposed surface. As the cold water is displaced from the top, it sinks down and around to be continuously rewarmed. **Freezing of the exposed surface water is eliminated to at least -40°C.**

EASY MAINTENANCE

To service, simply turn off the water and electric connections at source and remove four screws to remove the side access plate. The electric, water joints and the electric and water components are then easily accessible.

SIMPLE INSTALLATION

In the field/outdoors

The Aqua Bowl is designed to fit securely into the end of a standard 10" galvanized culvert. After digging a trench to below the frost line (approx 1.25 metres or 4' depth), lay a half inch PVC water line and underground grade electric line through a four inch 'Big O' tubing, from source to font position. Install a standard 10" diameter, 7' length of galvanized culvert on its end with 4' below grade and 3' above.

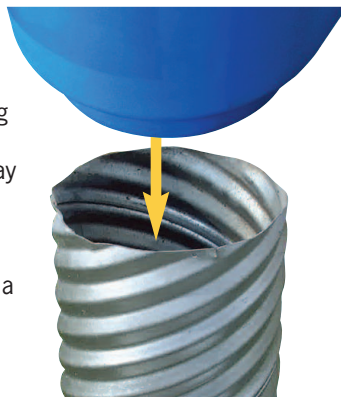

In the stall

The Aqua Bowl is designed to fit snugly into an optional bracket available from your dealer. Just mount the bracket within a stall, or between two stalls, at an appropriate height. Seat the font into the bracket and secure it with four screws provided. Then connect an electric line, and a heated water line for easy hook-up, per instructions.

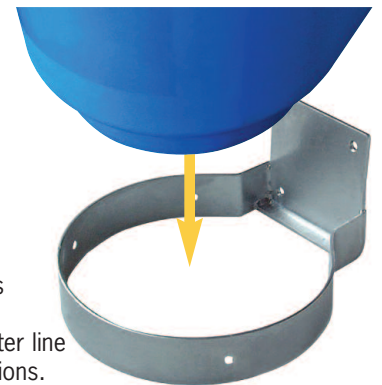

COMPONENTS



BOWL

Made of double walled, heavy gauge, non-toxic poly. Won't crack in freezing conditions. No sharp edges. It replenishes often to keep the water fresh.

PROTECTOR PLATE

Secure enough that cows can't budge it, but easily slides out by hand for bowl cleaning and inspection.

SIDE ACCESS PLATE

Unscrews for ease of servicing.



POSITIVE ACTION FLOAT VALVE ASSEMBLY

Firmly attaches water line to float valve. Valve is adjustable.

It is easy to access and is made of durable plastic with positive stop valve.



THERMOSTAT

Immersed in water to maintain water temperature between 3°C and 15°C in freezing conditions.

HEATING ELEMENT

Rated at 70 watts, the heating element keeps water circulating for even temperature control. Good to, at least -50°C.

ELECTRICAL COMPONENTS THERMOSTAT, HEATING ELEMENT, WIRES

All electrical components are sealed in epoxy to prevent shocks. Replaced only as an all-inclusive unit.

- .92 AMPS

WIRES

A 4 foot, 3 prong, power cord and a 6' 4" water line heating wire are provided for installation. Rated at 40 watts, the cable is taped to the water line in the watering bowl, and then inserted in a foam sleeve over the water line to a depth of 4.5' below grade.



WARRANTY

CANARM Ltd. warrants every new **AQUA BOWL** to be free of defects in material and workmanship, to the extent that, within a period of one year from the date of purchase CANARM Ltd. shall either repair or replace at CANARM's option, any unit or part thereof, returned freight prepaid, and found to be defective.

This warranty does not include any labour or transportation costs incidental to the removal and reinstallation of the unit at the user's premises.

Components repaired or replaced are warranted through the remainder of the original warranty period only.

This warranty applies to the original purchaser-user only; it is null and void in case of alteration, accident, abuse, neglect, and operation not in accordance with instructions.

NOTICE: No warranty claims will be honored by **CANARM Ltd.** unless prior authorization is obtained.

ASSEMBLY

- * CAPACITIES: 4 FT = 21 Gals at recommended 7" water depth
6 FT = 28 Gals at recommended 7" water depth
8 FT = 38 Gals at recommended 7" water depth

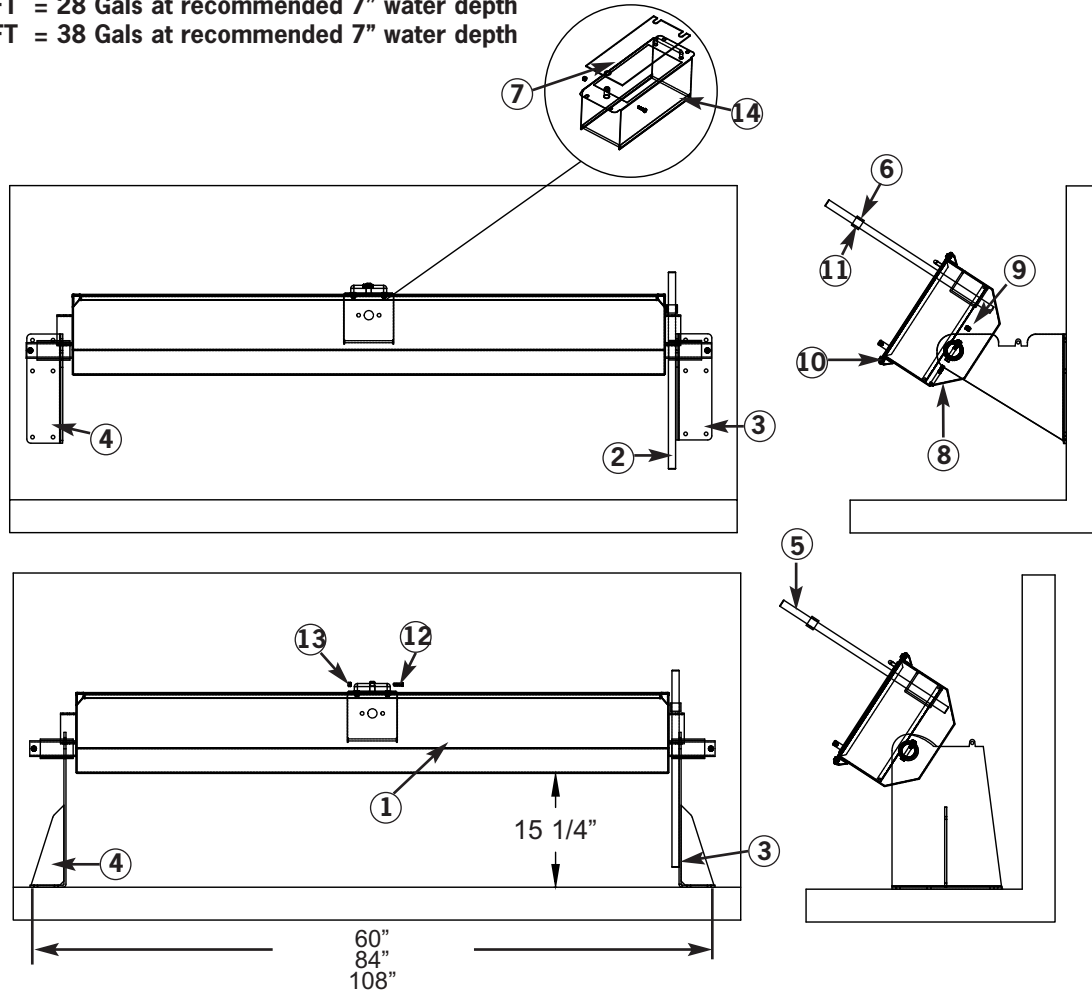

ILLUS.	DESCRIPTION	PART #	PACKAGE NAME
* 1	SS TIP TROUGH ONLY (10" H) 48" 72" 96"	1603048 1603072 1603096	SS TIP TROUGH
2	1" ROD GALV HANDLE ONLY /TROUGH	1600130	HANDLE MOUNTS FLOOR
3	GALVANIZED RIGHT FLOOR MNT BRACKET/TROUGH	1600500FR	
4	GALVANIZED LEFT FLOOR MNT BRACKET/TROUGH	1600500FL	
2	1" ROD GALV HANDLE ONLY /TROUGH	1600130	HANDLE MOUNT WALL
3	GALVANIZED RIGHT WALL MNT BRACKET/TROUGH	1600500WR	
4	GALVANIZED LEFT WALL MNT BRACKET/TROUGH	1600500WL	
5	BLUE PLASTIC HANLE GRIP	1600131	SS HDW + COVER PLATE 1603410
6	1" LG COLLAR/TROUGH HANDLE	1600134	
7	STAINLESS STEEL COVER PLATE		
8	3/8" X 2-1/2" HEXBOLT SS	BOL3/8-21/22H	
9	3/8" NYLON INSERT LOCK NUT SS	NUT3/8LSS	
10	1/4" X 1-5/8" LG LYNCH PIN	2060633	
11	1/4" X 3/8" SS HEX BOLT	BOL1/4-3/8HSS	
12	1/4-20 X 1 SS HEXBOLT	BOL1/4-1HSS	
13	1/4-20 N.I.LOCK NUT SS 304	NUT1/4LSS	
14	FLOAT GUARD ONLY (BOLT IN) FOR TIP TROUGH	1603072CH	

ASSEMBLY

* CAPACITIES: 10 FT = 46 Gals at recommended 7" water depth
12 FT = 55 Gals at recommended 7" water depth

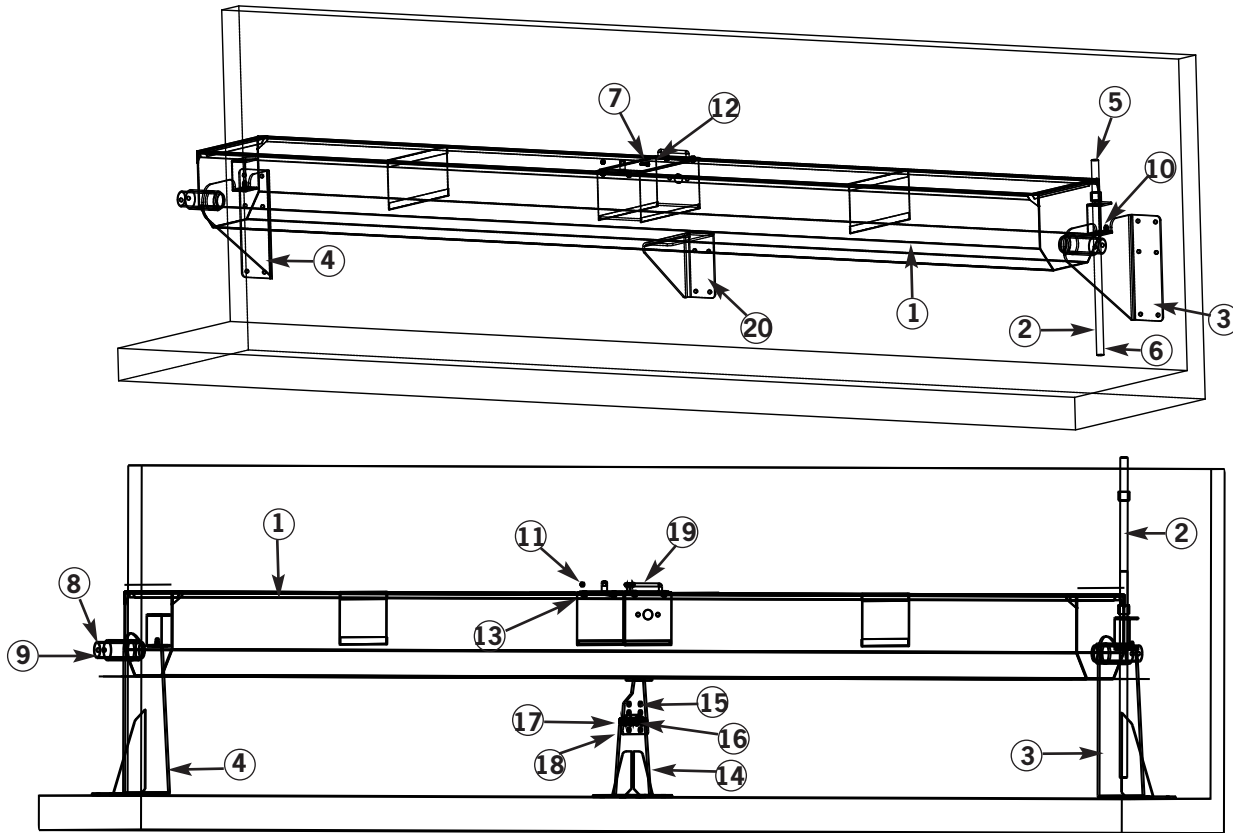

ILLUS.	DESCRIPTION	PART #	PACKAGE NAME
* 1	SS TIP TROUGH ONLY (10" H) 120" 144"	1603120 1603144	SS TIP TROUGH
2	1" ROD GALV HANDLE ONLY /TROUGH	1600130	HANDLE MOUNTS FLOOR
3	GALVANIZED RIGHT FLOOR MNT BRACKET/TROUGH	1600500FR	
4	GALVANIZED LEFT FLOOR MNT BRACKET/TROUGH	1600500FL	HANDLE MOUNT WALL
2	1" ROD GALV HANDLE ONLY /TROUGH	1600130	
3	GALVANIZED RIGHT WALL MNT BRACKET/TROUGH	1600500WR	SS HDW + COVER PLATE 1603410
4	GALVANIZED LEFT WALL MNT BRACKET/TROUGH	1600500WL	
5	BLUE PLASTIC HANDLE GRIP	1600131	CENTRE SUPPORT + HDW
6	1" LG COLLAR/TROUGH HANDLE	1600134	
7	STAINLESS STEEL COVER PLATE		
8	3/8" X 2-1/2" HEXBOLT SS	BOL3/8-21/22H	
9	3/8" NYLON INSERT LOCK NUT SS	NUT3/8LSS	FLOOR GUARD
10	1/4" X 1-5/8" LG LYNCH PIN	2060633	
11	1/4" X 3/8" SS HEX BOLT	BOL1/4-3/8HSS	CENTRE SUPPORT + HDW
12	1/4-20 X 1 SS HEXBOLT	BOL1/4-1HSS	
13	1/4-20 N.I. LOCK NUT SS 304	NUT1/4LSS	
14	BASE FOR ADJ CENTRE REST	1600500-BASE	
15	ADJUSTABLE CENTRE REST (TIP TROUGH)	1600500-ADJ	WALL MOUNT CENTER SUPPORT
16	1/2" X 1 1/2" HEX BOLTS	BOL1/2-13/4H	
17	1/2" NYLON INS LOCK NUT	NUT1/2LN	
18	1/2" FLAT WASHER	WAS1/2	
19	FLOAT GUARD ONLY (BOLT IN) FOR TIP TROUGH	1603072CH	FLOOR GUARD
20	GALVANIZED WALL MNT CENTRE SUPPORT	1600500W	WALL MOUNT CENTER SUPPORT

TIP TROUGH REPLACEMENT PARTS



1500108

3/4" MF STREET ELBOW (8 GPM & 21 GPM))



1500110

Reduced Assembly (8 GPM & 21 GPM))



1500103

3/4" BARBED ADAPTER (8 GPM & 21 GPM))

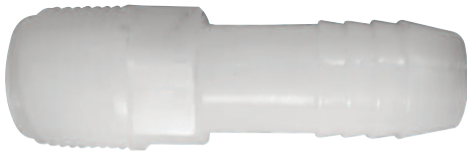

1600129-3

LINK ARM (21 GPM)



1500201

PLASTIC FLOAT VALVE (13 GPM)



1600127-2017

5" FLOAT BALL FOR 1600125 VALVE



1500100

PLASTIC FLOAT VALVE (13 GALLONS / MIN) + HDW

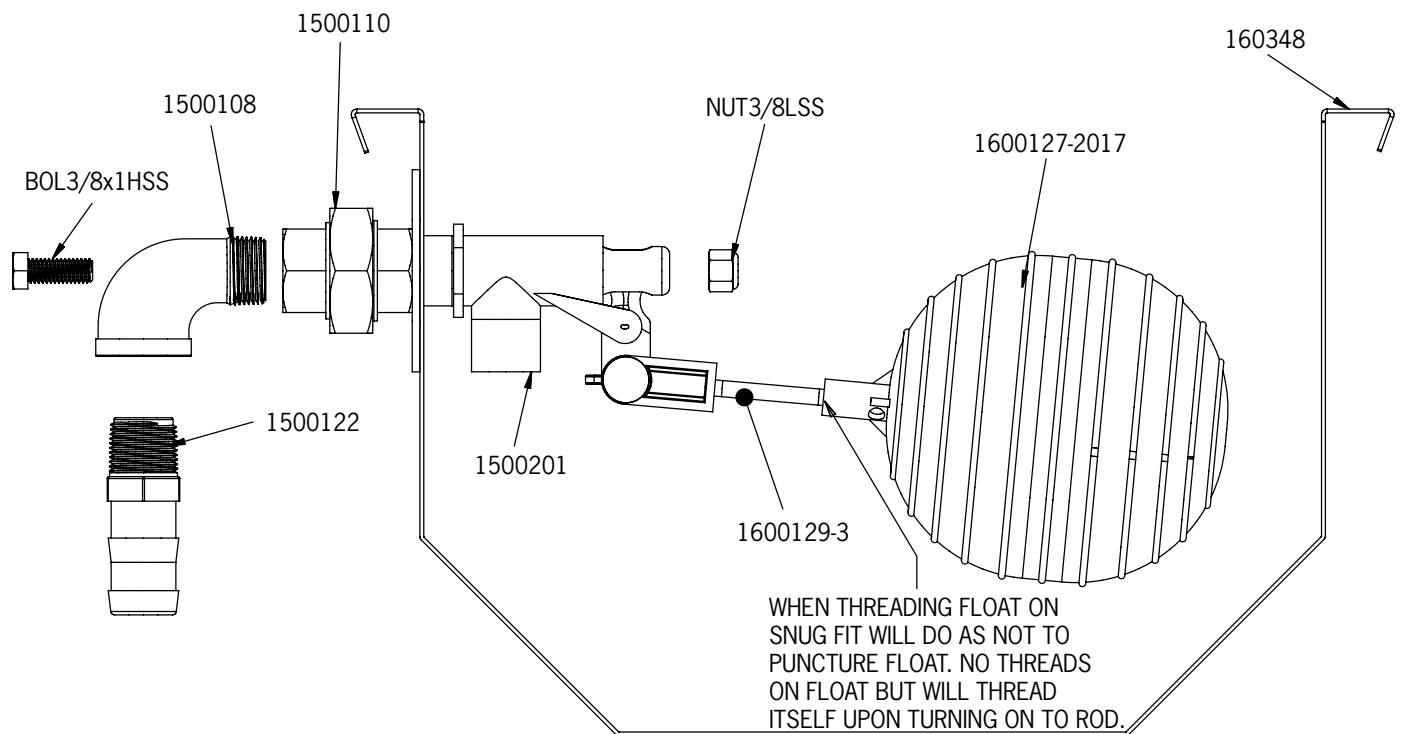

GENERAL COMPONENTS

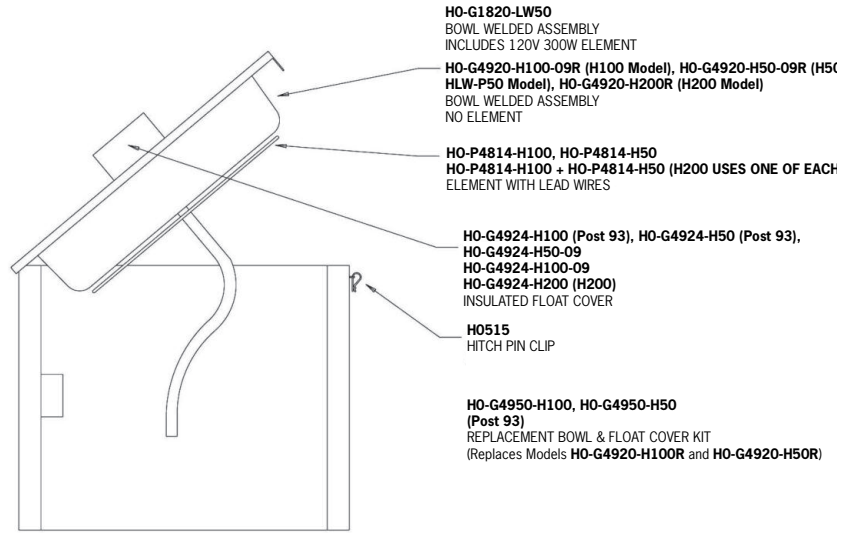

ELECTRICAL COMPONENTS

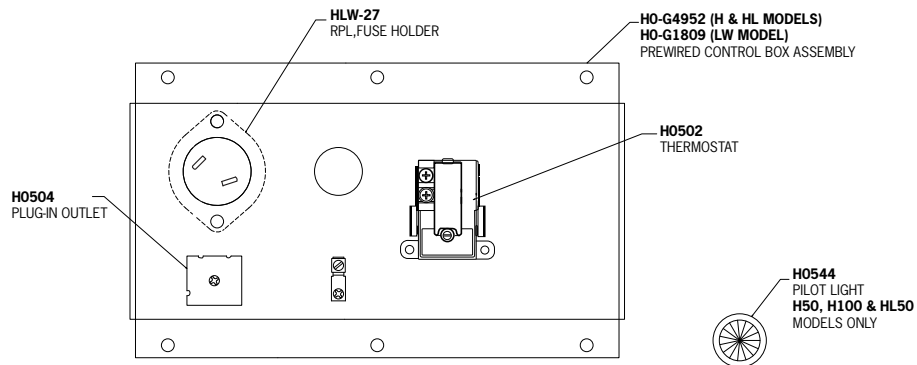

WATER SUPPLY COMPONENTS

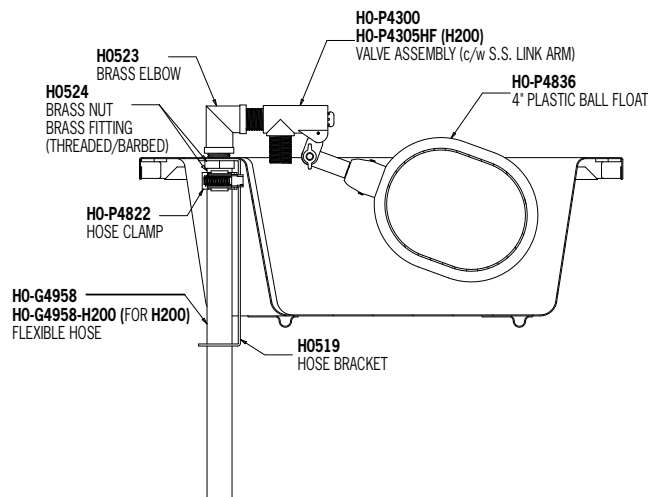

HO-G4920-H100-09R
REPLACEMENT BOWL - H100 (POST 2008)

HO-G4920-H50-09R
REPLACEMENT BOWL - H50 (POST 2008)

HO-G4920-H200
REPLACEMENT BOWL - H200

HO-G1820-LW50
REPLACEMENT BOWL - LW50



HO-G4950-H100
H100 (All model years)
HO-G4950-H50
H50 (All model years)
**REPLACEMENT BOWL
& FLOAT COVER KIT**



*Post 2008 style shown above

HO-G4924-H100
FLOAT COVER - H100 (POST '93) INSULATED

HO-G4924-H50
FLOAT COVER - H50 (POST '93) INSULATED

HO-G4924-H100-09
FLOAT COVER - H100 (POST 2008) INSULATED

HO-G4924-H50-09
FLOAT COVER - H50 (POST 2008) INSULATED

HO-G4924-H200
FLOAT COVER - H200 (POST 2008) INSULATED

HO-G4958
FLEXIBLE SUPPLY HOSE
(POST '93)

HO-G4958-H200
FLEXIBLE SUPPLY HOSE
(H200 MODELS)



HO-P4822
(#10 GEAR CLAMP, HF10)
HOSE CLAMP



HO-G4952
CONTROL BOX PRE-WIRED
(H, HL MODELS ONLY)

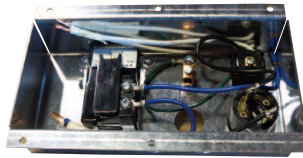

H0502
THERMOSTAT

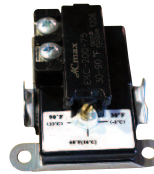

HLW-27
FUSE HOLDER



H0514
HOLD DOWN BRACKET +
HDW. (POST '93)



H0519
HOSE BRACKET HLW-93



H0523
H0523 BRASS ELBOW
(HLW-94)



H0524
H0524 BRASS FITTING &
NUT



H0544
ROUND PILOT LIGHT (KIT)
(POST '92)



HO-P4300
VALVE ASSEMBLY (KERICK)
C/W LINK ARM FOR FLOAT

HO-P4836
4" PLASTIC BALL FLOAT

HO-P4305HF (H200 MODEL)



HO-P4301
VALVE CUP & TIP SEAL KIT



HO-P4814-H100
ELEMENT (500 WATTS) - H100 (POST '93), 19" X 11"

HO-P4814-H50
ELEMENT (300 WATTS) - H50 (POST '93), 16" X 7"

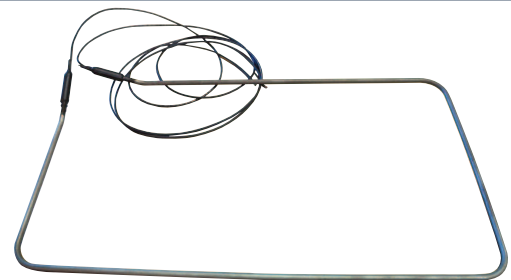

H200 Model uses one of each of the above.

HEATED LIVESTOCK WATERERS VALVE & FLOAT

Illustration #1

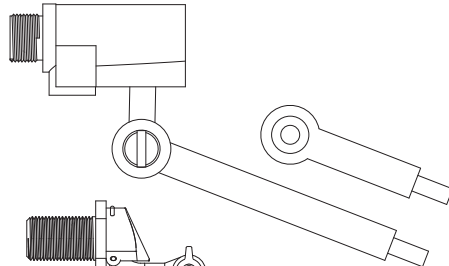

- (1) **Part#: H0511 / H0512**
No longer available.
Upgrade to newer valve (**Illustration #3**) is recommended.

Illustration #2

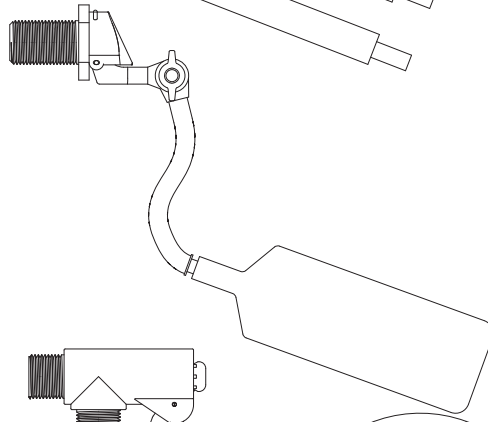

- (2) **Part#: H0-P4200 / H0-P4201**
No longer available.
New valve (**Illustration #3**) replaces valve shown in **Illustration #2**.

Illustration #3

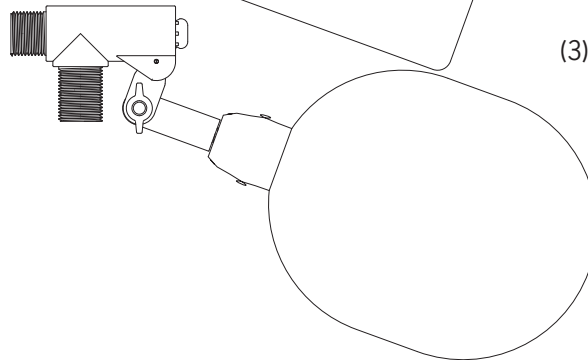

- (3) **Part#: H0-P4300** Available and current default valve (5.5 GPM @ 30 PSI)
Part #: H0-P4305HF for H200 model (12 GPM @ 30 PSI)

Float: H0-P4836

- 2001** Post-1994 valve assembly (see **Illustration #1**) required costly design upgrade for high water pressure (PSI) locations. Research thus began for alternate valves.
- 2003** An alternate valve (see **Illustration #2**) was found, tested and approved to cover high PSI locations with fair results for low PSI locations. Decision was made to completely switch to this valve.
- 2005** Feedback indicated that low PSI locations needed greater water flow. Valve supplier was immediately contacted for further development. In the interim however, low PSI users were told to purchase the post-1994 valve (**Illustration #1**) with an updated plastic float as a replacement assembly.
- 2006** A redesigned, more robust valve (**Illustration #3**) with improved sealing and a larger orifice size (with capacity for further enlargement) was soon developed, tested and approved. All 2006 waterers will have this new valve (**Illustration #3**).
- 2009** A high flow valve has been added for the H200 waterer. It is rated for 12 gal/min at 30 psi. See replacement part #H0-P4305HF. It is retro-fittable to older models.

CANARM LTD. - Corporate Office
2157 Parkedale Ave., Brockville, ON
Canada K6V 5V6
Tel: (613) 342-5424 Fax: 1-800-263-4598

CANARM LTD. - USA Warehouse
808 Commerce Park Drive
Ogdensburg, New York, USA 13669
Tel: 1-800-267-4427 Fax: 1-800-263-4598
Web Site: www.canarm.com
E-Mail: agsales@canarm.ca

Arthur Manufacturing Facility
#7686 Concession 16, RR 4 Arthur, ON
Canada NOG 1A0
Tel: (519) 848-3910 Fax: (519) 848-3948

TROUGHS

1. **Order trough** - Specify length
2. **Order fill system** - Standard plastic float (13 GPM)

